

Best Sound

FM STEREO TUNER

WARRANTY STATION MR 71 SERVICE MANUAL

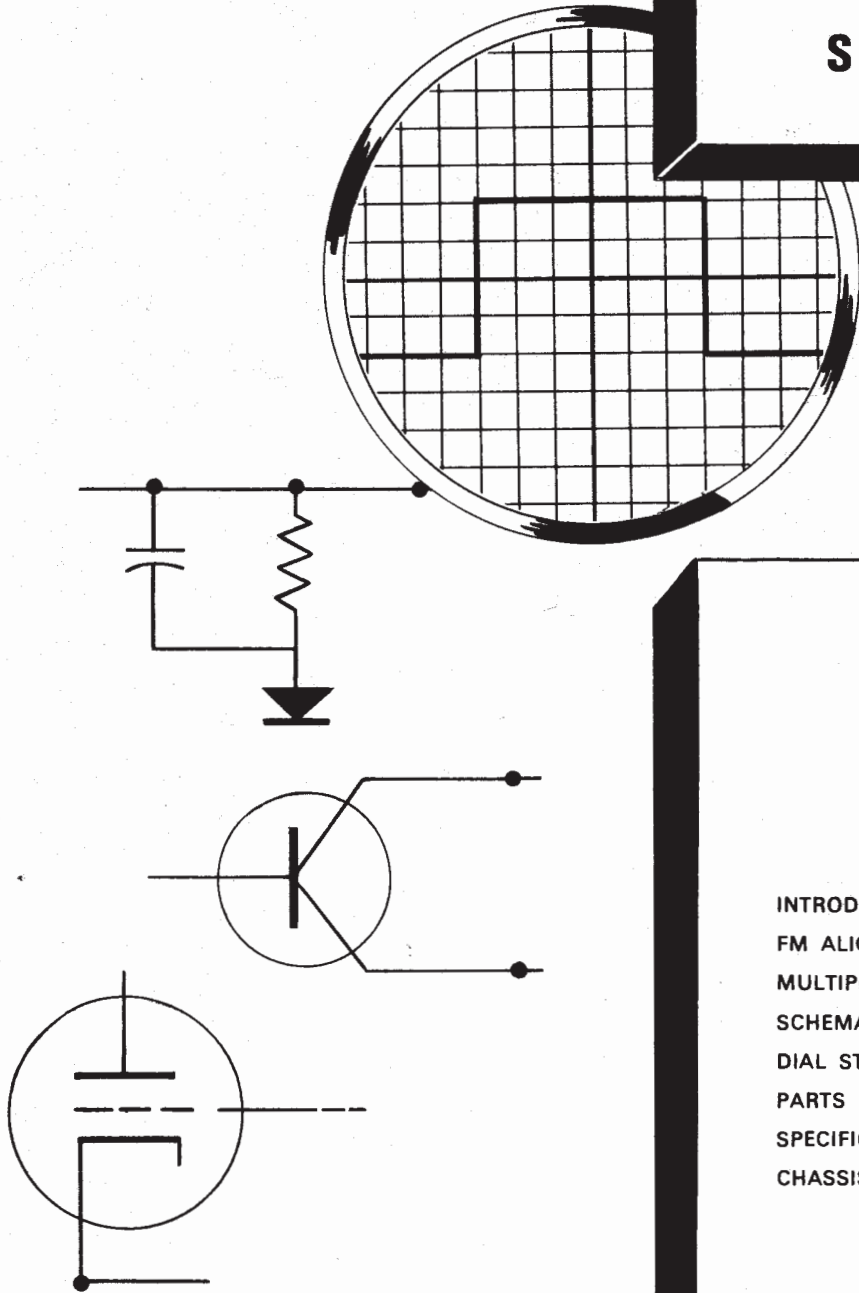

CONTENTS

INTRODUCTION.....	1
FM ALIGNMENT.....	2
MULTIPLEX ALIGNMENT.....	4
SCHEMATIC.....	6
DIAL STRINGING.....	8
PARTS LIST.....	9
SPECIFICATIONS.....	12
CHASSIS LAYOUT.....	12



2 CHAMBERS ST.
BINGHAMTON, N.Y.

McIntosh MR 71

MR 71 FM STEREO TUNER

INTRODUCTION

All McIntosh tuners are carefully aligned and tested at the factory using the finest available test equipment. All McIntosh tuners will meet their published specifications when shipped from the factory.

After extensive operation, especially when tubes have been replaced, it may be desirable to realign the tuner circuits for best performance. This manual gives complete information on the circuit realignment procedure for the MR 71 stereo tuner.

The test equipment listed below (or its equivalent) is necessary to properly align an MR 71. The accuracy of the alignment will be directly related to the accuracy and calibration of the test equipment used.

FM Signal Generator (Measurements 210A or equivalent)

VTVM

Multiplex Generator (RCA WR-51A or equivalent)

10.7 MC Generator (Preferably crystal controlled)

Oscilloscope (Hewlett-Packard 120B or equivalent)

Harmonic Distortion Analyzer, desirable but not essential—
(Hewlett-Packard 330B or equivalent)

If the necessary test equipment is not available, alignment should not be attempted. You may contact the McIntosh Customer Service Department for additional information.

Customer Service
McIntosh Laboratory, Inc.
2 Chambers Street
Binghamton, New York

Our telephone number is 723-5491

The direct dial area code is 607

MR 71 FM

STEPS	TUNER DIAL SETTING	SIGNAL GENERATOR			INDICATOR	
		FREQ	COUPLING	MODULATION	TYPE	CONNECTED TO
1	Point of no interference or signal	10.7MC	Through external .01MF cap to pin 7 of 12AT7 mixer	CW	VTVM	TP #1
2	SAME	SAME	SAME	SAME	SAME	Pin 6 of T5
3	SAME	SAME	SAME	SAME	SAME	Junction of D4 and R42
4	SAME	SAME	SAME	SAME	SAME	T6, Pin 6
5	SAME	SAME	SAME	SAME	SAME	TP #2
6	105MC	105MC	300 ohm antenna terminals with *matching network	400 cycles 75KC deviation (100% modulation)	VTVM connected to TP1 and scope connected to L or R audio output	
7	90MC	90MC	SAME	SAME		SAME
8	105MC	105MC	SAME	SAME		SAME
9	90MC	90MC	SAME	SAME		SAME
10	Point of no interference				Scope	L or R output
11	105MC	105MC	SAME	400 cycles 75KC deviation (100% modulation) attenuated to 2.5 microvolts output	VTVM connected to TP #1 and Scope connected to L or R audio output	

ANTENNA MATCHING NETWORK

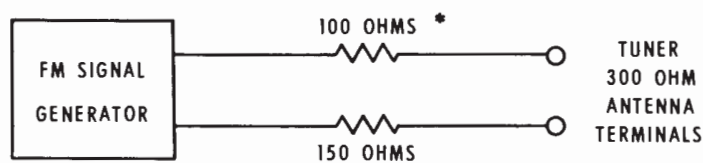

* IF SIGNAL GENERATOR HAS OTHER THAN 50 OHM INTERNAL IMPEDANCE, USE A RESISTOR OF 150 OHMS, LESS INTERNAL GENERATOR IMPEDANCE.

ALIGNMENT

ADJUST	TEST LIMITS	REMARKS
Top (Secondary) and bottom (Primary) cores of T1, T2, T3, and T4	Maximum possible negative voltage	Shunt to ground the winding not being adjusted with a .01MF capacitor in series with a 1K resistor. Attenuate signal generator until output voltage at TP #1 is less than 1.5 volts with one IF transformer winding shunted. IF transformers have terminal #1 marked with a green dot and are numbered clockwise.
T5 Primary (Bottom core)	Same as above	
T5 Secondary (Top core)	Adjust for 0 volts	
T6 Primary (Bottom core)	Maximum negative voltage	If a distortion analyzer is available, omit this step at this time. Adjust T6 primary after step 9. At that time, use a strong signal from FM generator, modulate 100%, and use 75KC deviation. Adjust primary for minimum distortion. Should be no greater than 0.5%.
T6 Secondary (Top core)	Adjust for 0 volts	
Oscillator Trimmer	Maximum negative voltage	As output increases, attenuate signal generator to keep maximum output at TP #1 to a low level. By doing so, precise alignment can be achieved.
Oscillator Coil	SAME	Repeat steps 6 and 7 until dial calibration is accurate.
Mixer trimmer, RF trimmer, and Antenna trimmer	SAME	
Mixer, RF, and Antenna coil Tuning slugs	SAME	Repeat steps 8 and 9 until output is as high as possible.
Muting adj. control		Turn muting switch to "in" position. Adjust muting control until background noise just disappears.
	IHFM sensitivity 2.5 microvolt for 3% total noise and distortion	Step 11 is an overall sensitivity check, and requires a distortion analyzer and FM signal generator with attenuator. With 2.5 microvolts input at the 300 ohm antenna terminals, TP #1 voltage should be 3.0 volts or more.

MR 71 MULTIPLEX

STEPS	TUNER DIAL SETTING	SIGNAL GENERATOR			INDICATOR	
		FREQ.	COUPLING	MODULATION	TYPE	CONNECTED TO
1						
2	100MC	100MC modulated by MPX generator	300 ohm antenna terminals with approx. 1000 microvolt signal	19KC pilot only	DC VTVM	Pin 7 of 6U8 (V14B)
3						
4	SAME	SAME	SAME	1KC 100% modulation left or right only, pilot on	Audio VTVM	Pin 1 or 2 of 38KC transformer (T8)
5	SAME	SAME	SAME	SAME	Audio VTVM and scope	L or R output jack
6	SAME	SAME	SAME	SAME	SAME	SAME
7	SAME	SAME	SAME	SAME	SAME	SAME
8	SAME	SAME	SAME	Turn off 1KC audio modulation	SAME	SAME
9	SAME	Tune to a strong MONO FM station	SAME		MPX stereo indicator light on tuner	

DECODER ALIGNMENT

ADJUST	TEST LIMITS	REMARKS
		On the top of the chassis is an opening labeled "MPX Light Adjust." Insert a screw driver into this opening and turn the control completely counterclockwise.
19KC phase coil and 19KC transformer (T7)	Adjust for maximum DC voltage	
		Adjust "MPX Light Adjuster" control completely clockwise.
38KC transformer bottom core	Adjust for maximum voltage	
38KC transformer top core	Adjust for stable scope display	<ol style="list-style-type: none"> 1. Turn off 19KC pilot on MPX generator. 2. Adjust top core of 38KC transformer to obtain a stable and uniform 1KC signal scope display. This adjustment may be critical, so turn core very slowly. 3. Turn 19KC pilot back on.
19KC phase coil	30db separation or more	Modulate left channel and measure right channel output. Adjust 19KC phase coil for minimum right channel output (maximum separation). Remove all test leads from TP #2 for separation checks.
	SAME	Modulate right channel and measure left channel output. Separation in steps 5 and 6 should be at least 30db.
		This step checks the rejection of 19KC and 38KC frequencies. Residual output should be at least 40db below modulated output.
MPX light adj. control—R3		Turn control until light comes on. Then back off just enough to cause the light to go off. Then back off about $\frac{1}{8}$ of a turn more. Light should operate ONLY on an MPX signal.

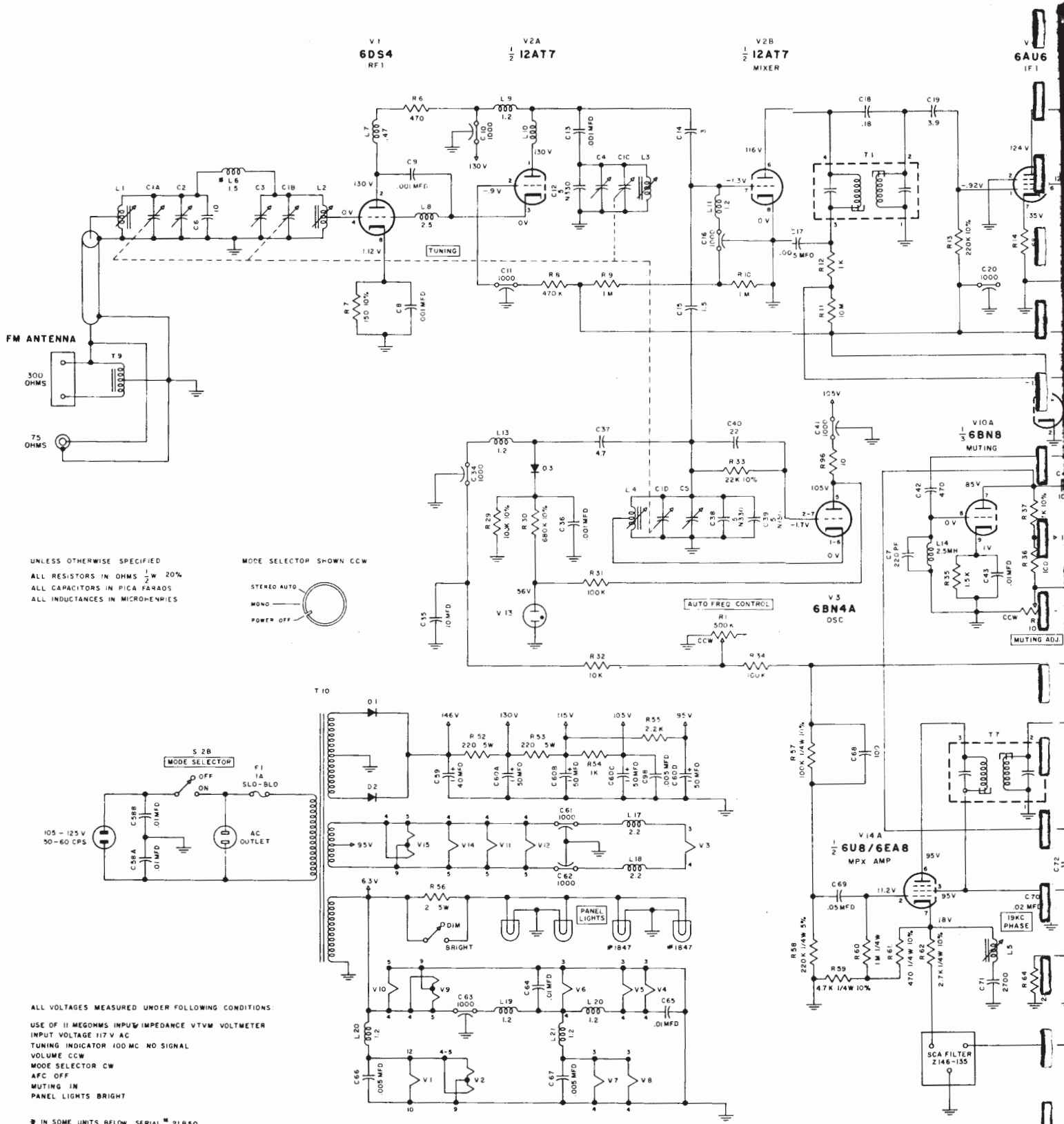

UNLESS OTHERWISE SPECIFIED
 ALL RESISTORS IN OHMS $\frac{1}{2}$ W 20%
 ALL CAPACITORS IN PICA FARADS
 ALL INDUCTANCES IN MICROHENRIES

MODE SELECTOR SHOWN CCW
 STEREO AUTO
 MONO
 POWER OFF

ALL VOLTAGES MEASURED UNDER FOLLOWING CONDITIONS:
 USE OF 11 MEGOHMS INPUT IMPEDANCE VTVM VOLT METER
 INPUT VOLTAGE 117 V AC
 TUNING INDICATOR 100 MC NO SIGNAL
 VOLUME CCW
 MODE SELECTOR CW
 AFC OFF
 MUTING IN
 PANEL LIGHTS BRIGHT

* IN SOME UNITS BELOW SERIAL # 21850
 L6 IS NOT USED AND L1 IS LINK COUPLED TO L2

T7

V2B
1 12AT7
2 MIXER

V
6AU6
IF 1

V5
6AU6
IF 2

V6
6AU6
IF 3

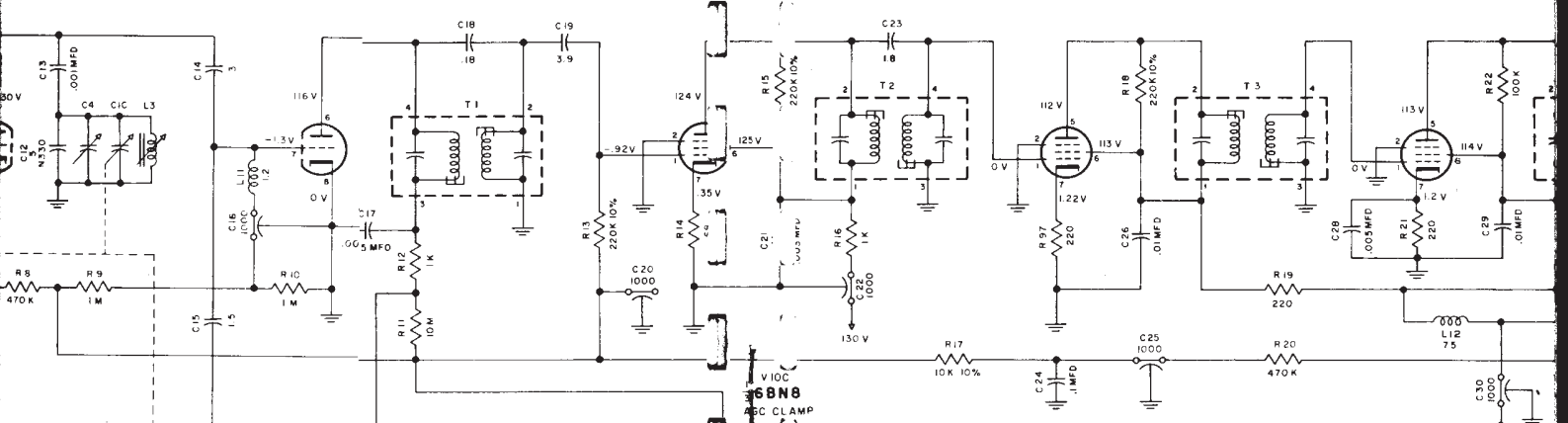

V10C
1 6BN8
ABC CLAMP

V7
6AU6
IF 4 L1M 1

V10A
1 6BN8
MUTING

V10B
3 6BN8

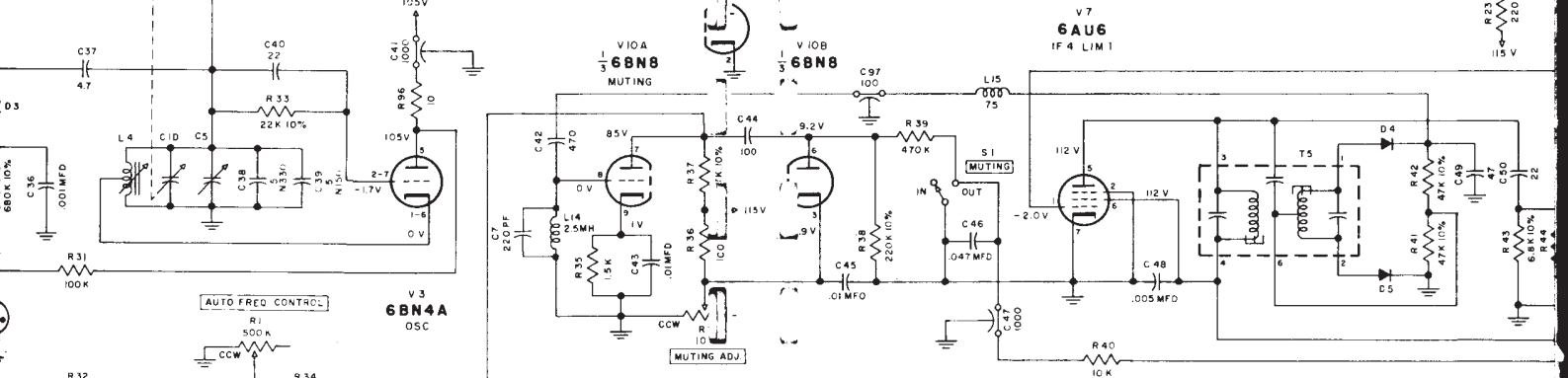

AUTO FREQ CONTROL

V3
6BN4A
OSC

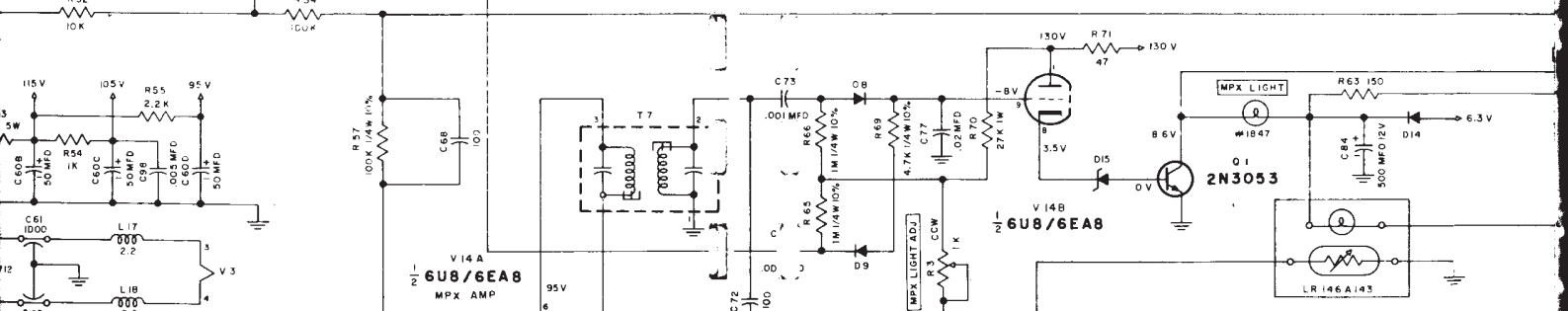

V14A
1 6B8/6EA8
MPX AMP

V14B
2 6B8/6EA8

O1
2N3053

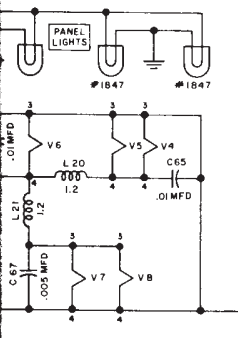
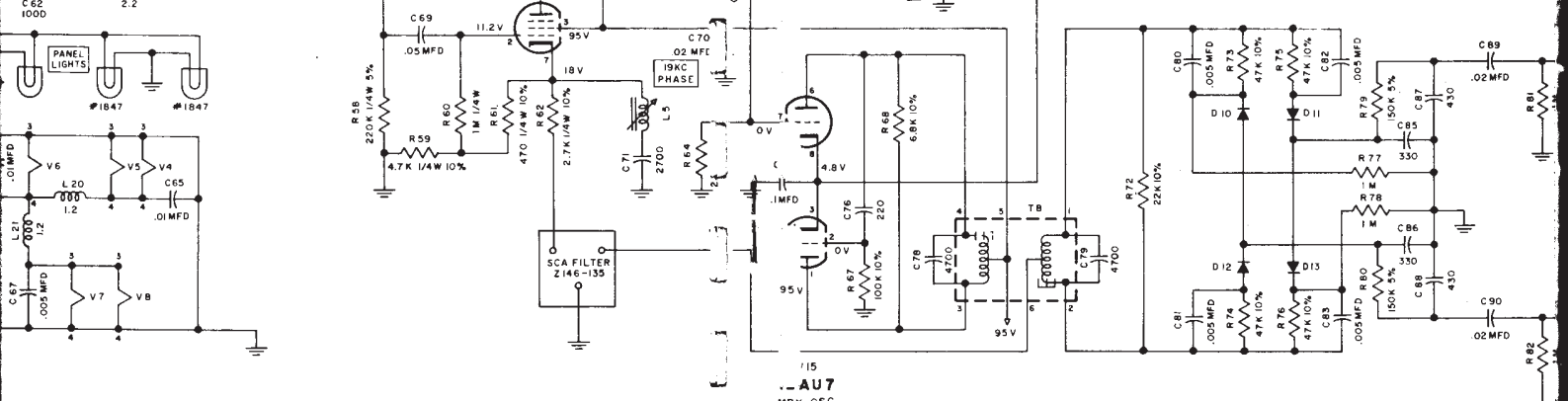

SCA FILTER
Z145-135

V15
1 AU7
MPX OSC

STARTING SERIAL # 20801

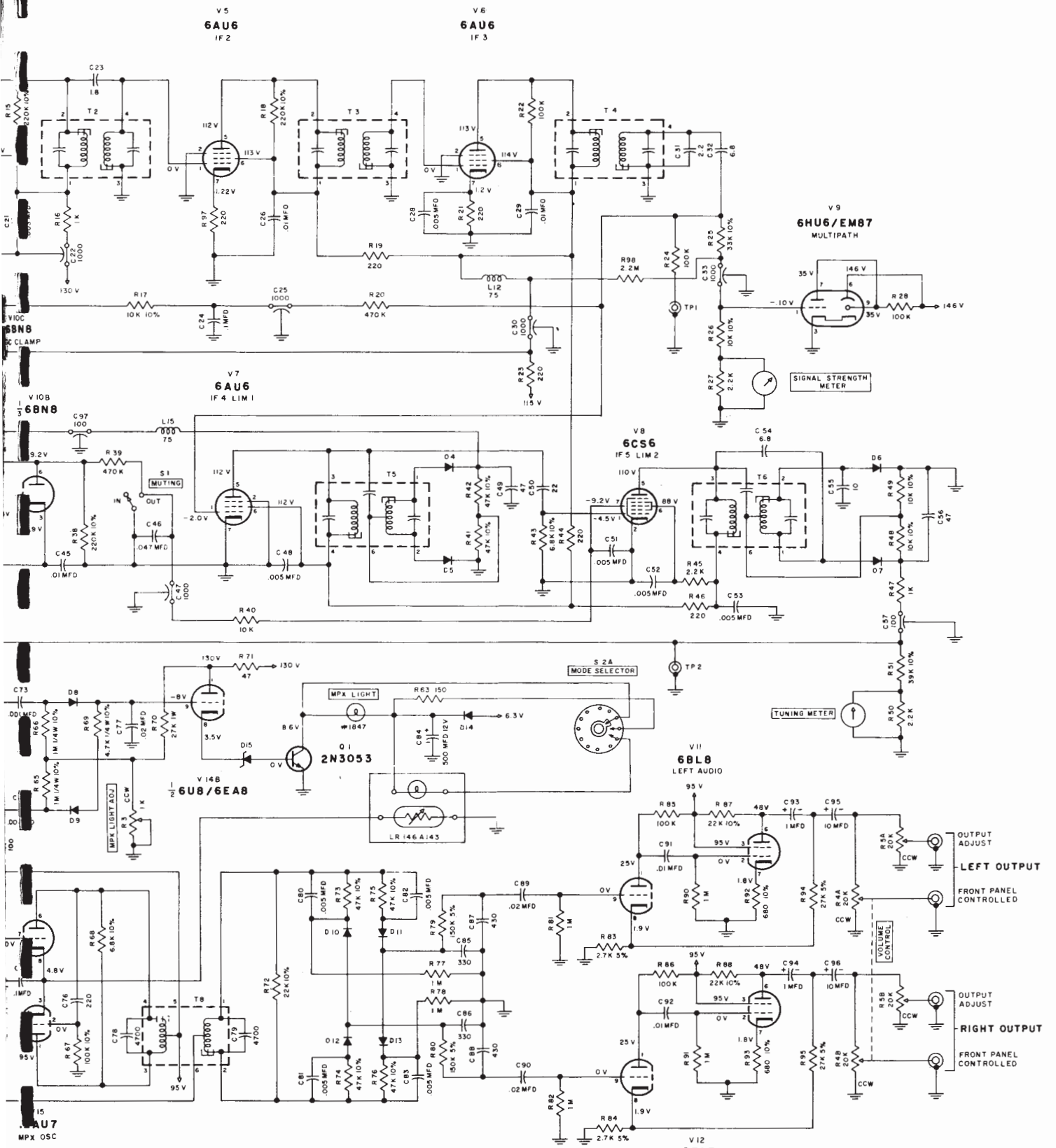

STARTING SERIAL # 20801

LAST R 98
LAST C 98
C27 IS NOT USED

SCHEMATIC, MR 71	
DATE	REV
DESIGNED BY	DATE
CHECKED BY	DATE
APPROVED BY	DATE
Mitsubishi LABORATORY INC. 1 Chiyoda-ku, Bldg. 2, 2-1-1, Chiyoda-ku, Tokyo, Japan	
DATE	REV
3.13.64	1
SC147E167	

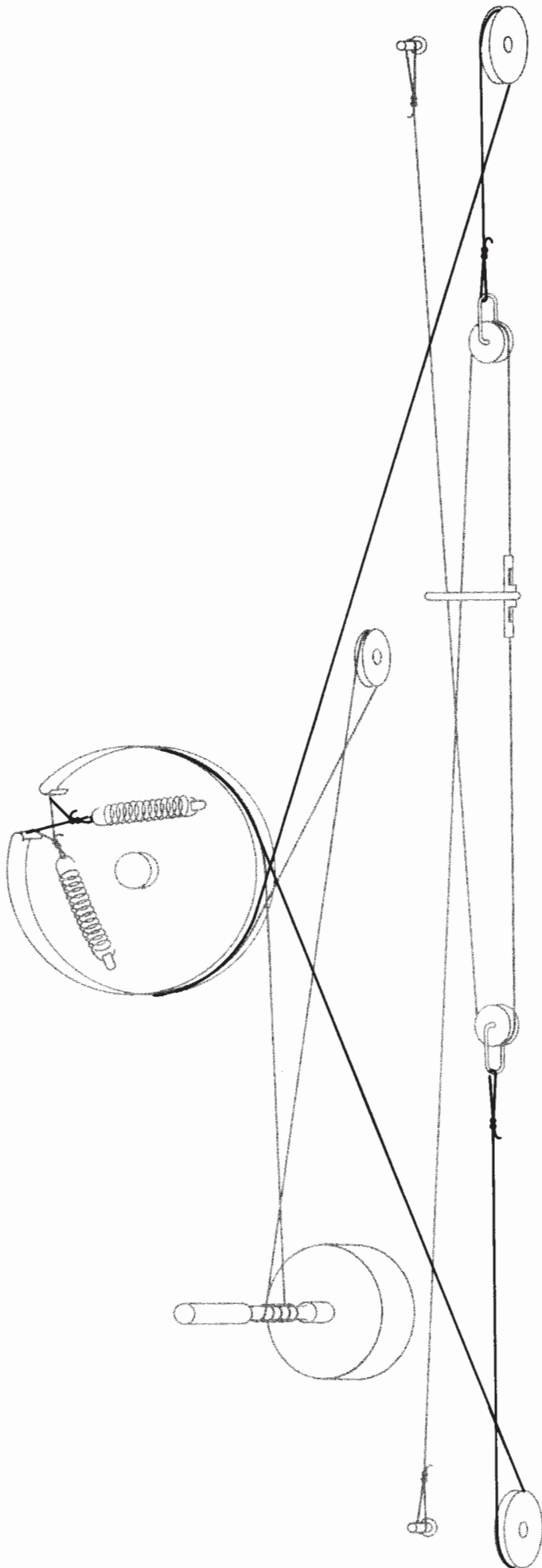

MR 71 PARTS LIST

TUBES

ITEM NO.	USE	IDENTIFICATION NUMBER
V1	RF Amplifier 1	6DS4
V2	RF Amplifier 2; Mixer	12AT7
V3	Oscillator	6BN4A
V4	IF Amplifier 1	6AU6
V5	IF Amplifier 2	6AU6
V6	IF Amplifier 3	6AU6
V7	IF Amplifier 4; Limiter 1	6AU6
V8	IF Amplifier 5; Limiter 2; Muting	6CS6
V9	Multipath Indicator	6HU6/EM87
V10	Muting Amplifier; Muting Detector; A&C Clamp	6BN8
V11	Left Audio Amplifier	6BL8
V12	Right Audio Amplifier	6BL8
V13	Voltage Reference Diode	ST2-27S
V14	MPX Amplifier, MPX Indicator Control	6U8
V15	MPX Oscillator	12AU7

TRANSISTOR

Q1	MPX Indicator Lamp Switch	2N3053
----	---------------------------	--------

DIODES

D1, D2	Selenium Rectifiers, High Voltage Power Supply	GE# 6RS20PH6RGD1
D3	Variable Capacitance	Amprex S-254
D4, D5	Narrow Band Discriminator (Matched Pair)	Type 1N542 Germanium Diode
D6, D7	Wide Band Discriminator (Matched Pair)	Type 1N542 Germanium Diode
D8, D9	Balanced Detector for MPX Indicator (Matched Pair)	Type 1N542 Germanium Diode
D10, D12	Balanced MPX Detectors—Left Channel (Matched Pair)	Type 1N542 Germanium Diode
D11, D13	Balanced MPX Detectors—Right Channel (Matched Pair)	Type 1N542 Germanium Diode
D14	Low Voltage Rectifier	Type 1N1217 Silicon Diode

CONTROLS

ITEM NO.	FUNCTION	RESISTANCE	IDENTIFICATION NUMBER
R1	Automatic Freq. Control	500K	R147-A103
R2	Muting Adj. Pot.	10K	R50, 000-6F
R3	MPX Light Adj.	1K	Wirt #807
R4	Volume Control	20K (Dual)	R105-164
R5	Rear Panel Output Adj. Control	40K (Dual)	R147-A102

SWITCHES

ITEM NO.	FUNCTION	DESCRIPTION	IDENTIFICATION NUMBER
S1	Muting	3 position	S147-B130
S2	Mode Selector	3 position with on/off switch	S147-B105
S3	Panel Light Dim-Bright	SPST	Stackpole SS-26

TRANSFORMERS

ITEM NO.	FUNCTION	IDENTIFICATION NUMBER
T1	FM first IF	T107-134A
T2	FM second IF	T107-133A
T3	FM third IF	T107-133A
T4	FM fourth IF	T107-133A
T5	FM fifth IF, Discriminator	T107-135B
T6	FM Discriminator	T107-135B
T7	19KC Amplifier	T129-101A
T8	38KC Oscillator	T129-102A
T9	Balun	
T10	Power	T123-133A

CAPACITORS

ITEM NO.	DESCRIPTION	CAPACITANCE	VOLTAGE	TOLERANCE	IDENTIFICATION NUMBER
C1	Variable FM				C147-C101
C2	Antenna Trimmer	1-8pf		NPO	
C3	RF Trimmer	1-8pf		NPO	
C4	Mixer Trimmer	1-8pf		NPO	
C5	Oscillator Trimmer	1-8pf			
C6	Ceramic Disc	10pf		20% NPO	
C7	Ceramic Disc	6.8pf		20% NPO	
C10	Ceramic Feed Thru	1000pf			
C12	Ceramic Tubular	5pf		±.25pf N330	
C14	Ceramic Tubular	3pf		±.25pf NPO	
C15	Ceramic Tubular	1.5pf		±.25pf NPO	
C16	Ceramic Feed Thru	1000pf			
C18	Phenolic	.18pf		10%	
C19	Phenolic	3.9pf		10%	
C20	Ceramic Feed Thru	1000pf			
C22	Ceramic Feed Thru	1000pf			

CAPACITORS

ITEM NO.	DESCRIPTION	CAPACITANCE	VOLTAGE	TOLERANCE	IDENTIFICATION NUMBER
C23	Phenolic	.33pf		10%	
C25	Ceramic Feed Thru	1000pf			
C27	Phenolic	.33pf		10%	
C30	Ceramic Feed Thru	1000pf			
C31	Phenolic	2.2pf		10%	
C32	Ceramic Disc	6.8pf		20% NPO	
C33	Ceramic Feed Thru	1000pf			
C34	Ceramic Feed Thru	1000pf			
C35	Non-Polarized Electrolytic	10mfd	25V	+100-10%	
C37	Ceramic Disc	.47pf		20% NPO	
C38	Ceramic Tubular	5pf		±.25pf N330	
C39	Ceramic Tubular	5pf		±.25pf N150	
C40	Ceramic Disc	22pf		20% N470	
C41	Ceramic Feed Thru	1000pf			
C42	Ceramic Disc	470pf		20%	
C44	Ceramic Disc	100pf		10% N1500	
C46	Paper	.047mfd	200V	20%	
C47	Ceramic Feed Thru	1000pf			
C49	Ceramic Disc	47pf		20% N470	
C50	Ceramic Disc	22pf		10% NPO	
C54	Ceramic Disc	6.8pf		20% NPO	
C55	Ceramic Disc	10pf		20% NPO	
C56	Ceramic Disc	27pf		20% N470	
C57	Ceramic Feed Thru	100pf			
C58	Ceramic Disc	2 x .01	900V AC		
C59	Electrolytic	40mfd	200V		
C60	Electrolytic	4 x 50mfd	200V		
C61	Ceramic Feed Thru	1000pf			
C62	Ceramic Feed Thru	1000pf			
C63	Ceramic Feed Thru	1000pf			
C68	Ceramic Disc	100pf		10% N1500	
C70	Paper	.0022mfd	400V	10%	
C71	Silver Mica	2700pf	100V	5%	
C72	Ceramic Disc	100pf		10% N1500	
C76	Ceramic Disc	220pf		20%	
C78	Silver Mica	4700pf	100V	5%	
C79	Silver Mica	4700pf	100V	5%	
C85	Ceramic Disc	330pf		10%	
C86	Ceramic Disc	330pf		10%	
C87	Ceramic Tubular	430pf		5%	
C88	Ceramic Tubular	430pf		5%	
C93	Electrolytic	1mfd	150V		C124-129
C94	Electrolytic	1mfd	150V		C124-129
C95	Electrolytic	10mfd	3V		
C96	Electrolytic	10mfd	3V		

COILS

ITEM NO.	DESCRIPTION	VALUE	IDENTIFICATION NUMBER
L1	Antenna Coil		L107A141
L2	RF Coil		L107-207A
L3	Mixer Coil		L107-208B
L4	Oscillator Coil		L107-206A
L5	19KC Trap		L129-103
L6	Coupling Link		
L7	RF Choke	.47 Micro H	
L8	RF Choke	2.2 Micro H	
L9	RF Choke	1.2 Micro H	
L10	RF Choke		L10, 004
L11	RF Choke	1.2 Micro H	
L12	RF Choke	.75 Micro H	
L13	RF Choke	1.2 Micro H	
L14	RF Choke	2.5 Micro H	M-7060
L15	RF Choke	.75 Micro H	
L16	Peaking Coil		L129-123
L17	RF Choke	2.2 Micro H	
L18	RF Choke	2.2 Micro H	
L19	RF Choke	1.2 Micro H	
L20	RF Choke	1.2 Micro H	
L21	RF Choke	1.2 Micro H	

MISCELLANEOUS

Lamp, Festoon: 7 volts, 2 watts, 7 x 43mm
 Lamp, Stereo: No. 1850
 Lamp, Meter: No. 1847
 Fuse: 1 Amp. Slo-Blo, 3AG
 Meter, Signal Strength: #M146B146

Meter, Tuning: #M146B148
 LDR Network: #R146-A143
 Cable, Coaxial: 50 ohm, Amphenol #21-598
 SCA Filter: #Z146B135

MR 71 TOP and BOTTOM VIEWS

MUTE ADJUST CONTROL

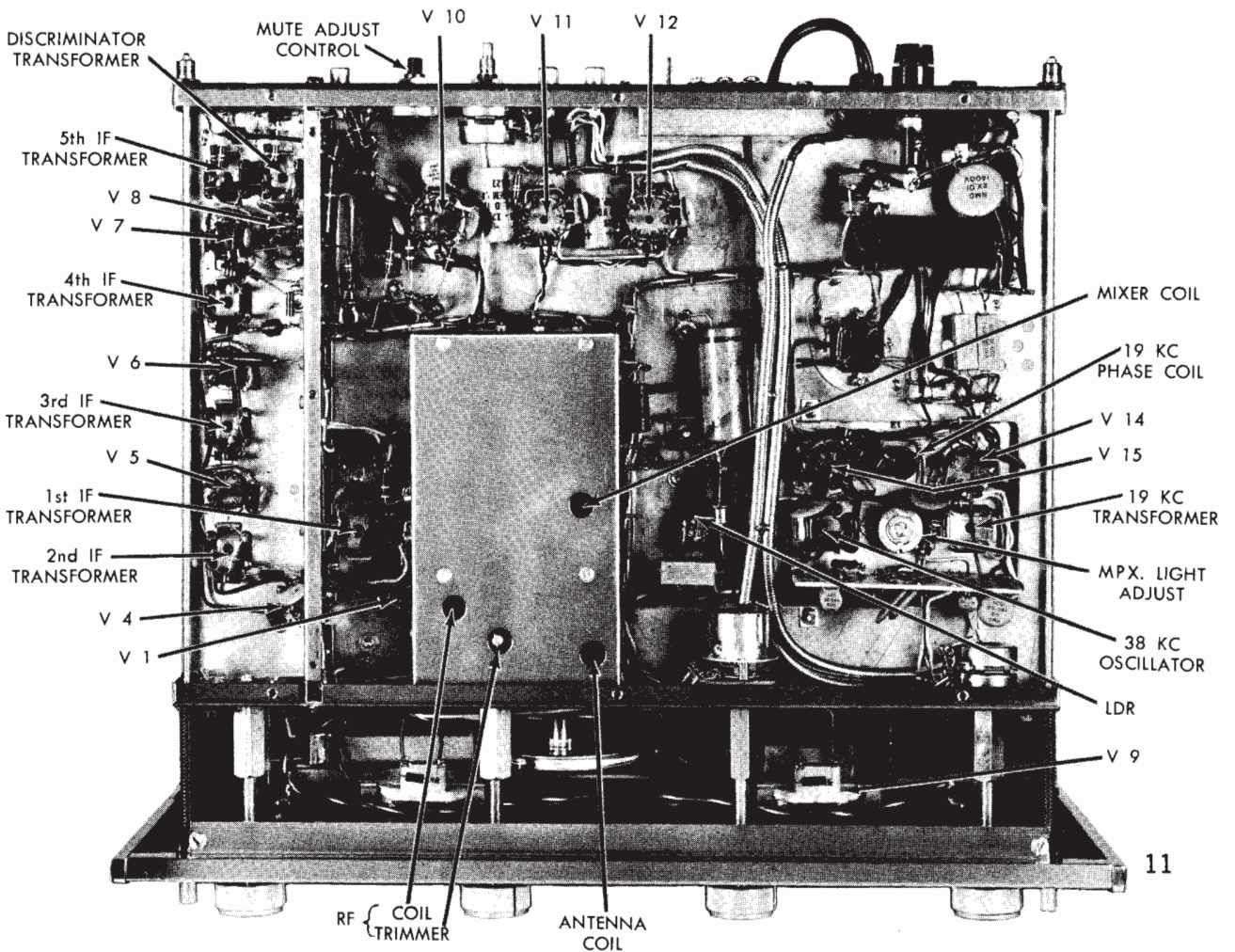
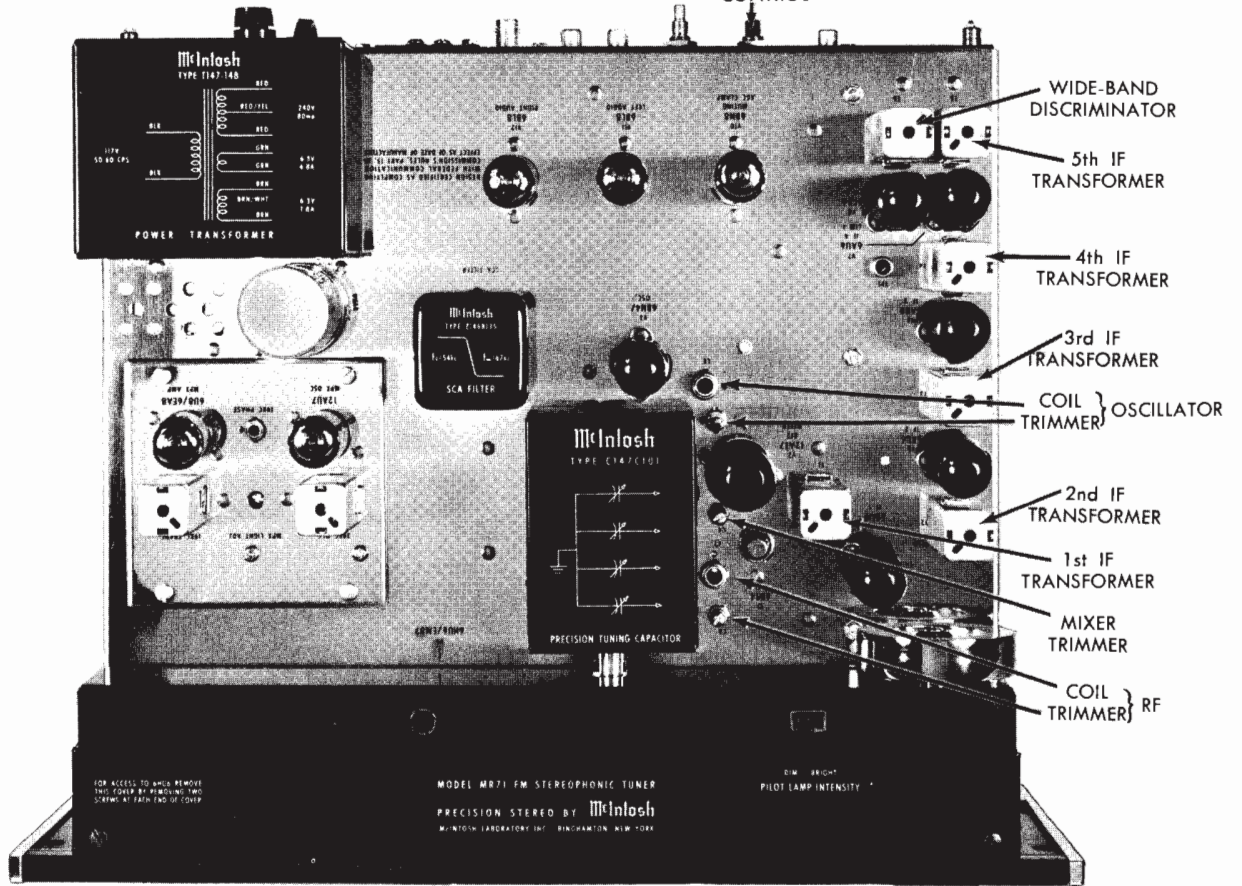

SPECIFICATIONS

Useable Sensitivity

2.5 microvolts at 100% modulation (± 75 KC deviation) for less than 3% total noise and harmonic distortion in accordance with IHF standards.

Audio Frequency Response

Within 1/2 db from 20 to 20,000 cycles.

Distortion

Less than 0.5% at 100% modulation ± 75 KC deviation.

Capture Ratio

1.5db at 100% modulation.

Muting

IF injected ultrasonic muting: at least 60db noise reduction between stations.

Oscillator Drift

Less than 25KC with AFC disabled; negligible with AFC in operation.

Image Rejection

Better than 80db at 90MC; better than 70db at 105MC.

Hum

Better than 70db below 100% modulation.

Output

Approximately 2.5 volts; low impedance.

Antenna Inputs

300 ohms balanced; 75 ohms unbalanced.

RF Amplifier

Cascode with 6DS4 Nuvistor in first stage.

IF Stages

Five, with 200KC bandwidth

Limiters

Two.

Radiation

Substantially below FCC requirements.

Multiplex Channel Separation

Better than 30db at 1000 cycles.

Multiplex Filter

Greater than 48db suppression of 19KC pilot and 38KC carrier.

Multiplex Indicator

Front panel multiplex stereo light activated by 19KC carrier-only.

Multiplex Type

Peak-detecting, self-matrixing detector.

SCA Filter

50db down at 67KC to 74KC 275db per octave slope.

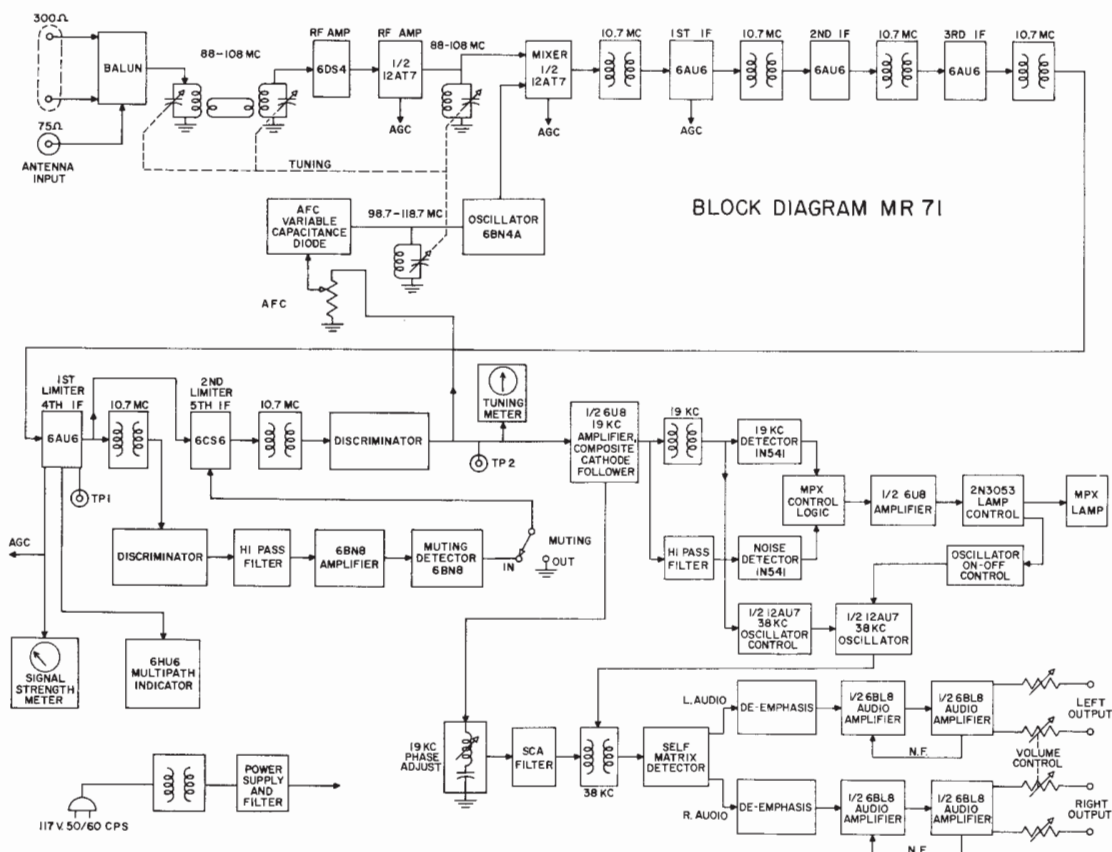

McIntosh

LABORATORY INC.

2 Chambers St., Binghamton, N. Y.

Made in U.S.A.

Phone—Area Code 607-723-5491

Design subject to change without notice.